

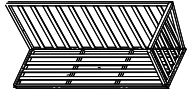







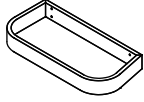

Assembly instruction

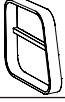
REF	PART NAME	PART IMAGE	QTY	REF	PART NAME	PART IMAGE	QTY
A	BACK BOARD		1	F	BOLT(M6X35)		4
B	TABLE LEG		1	G	BOLT(M6X15)		2
C	ARMREST		1	H	METAL WASHER		9
D	LEG		1	I	PLASTIC BOLT CAP		3
E	BOLT(M6X50)		3	J	ALLEN WRENCH		1



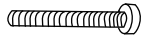

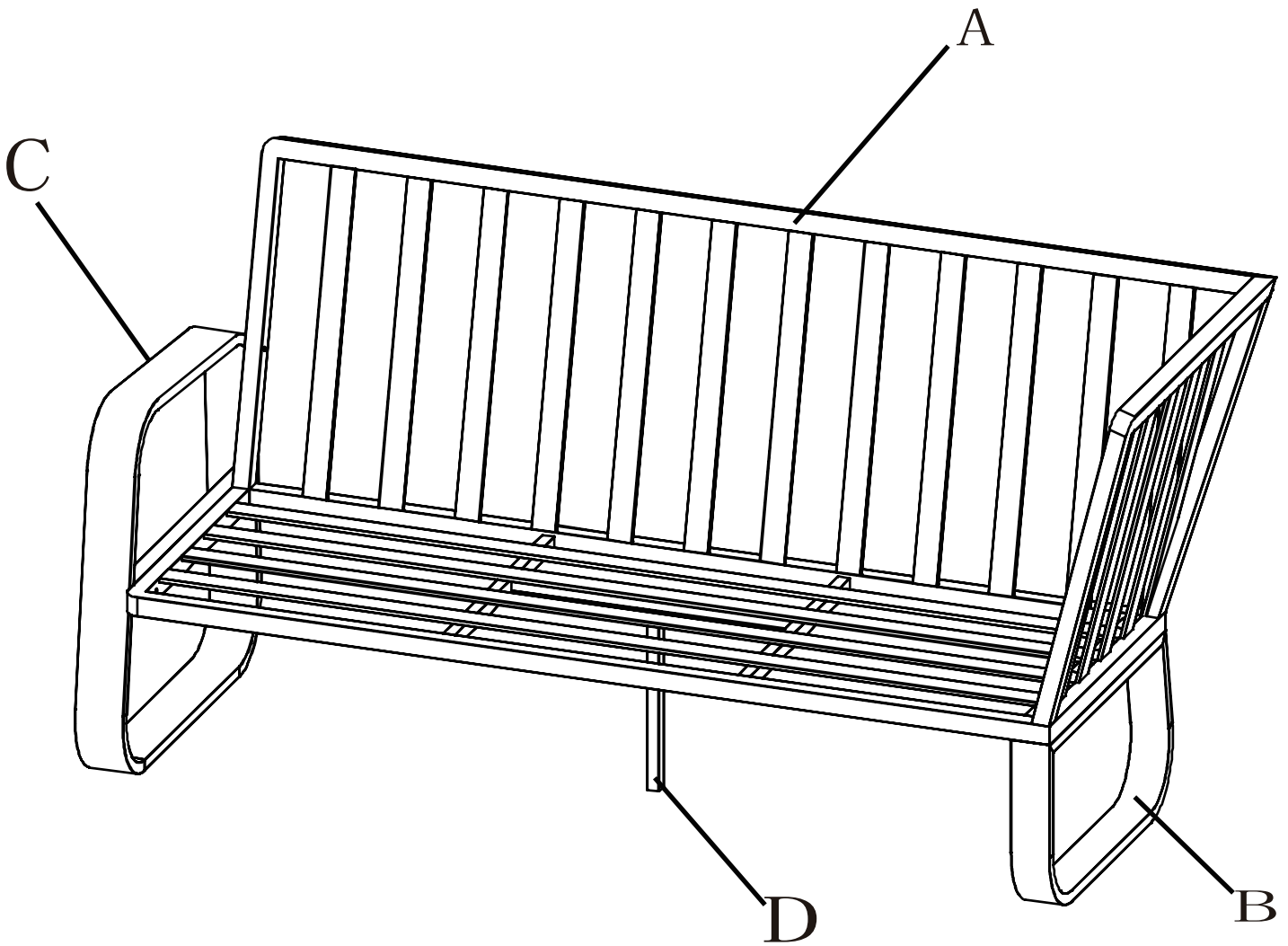
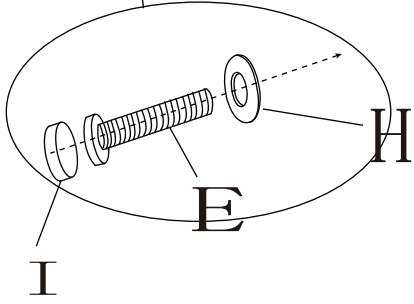
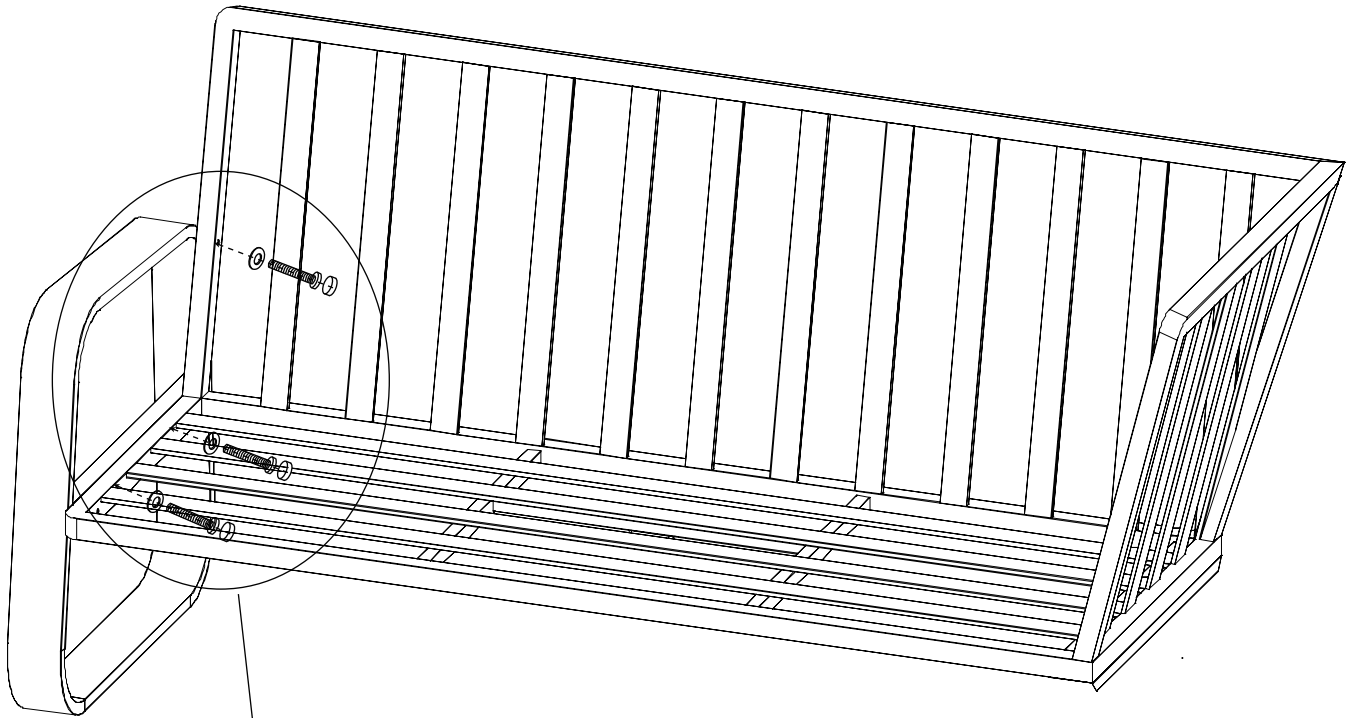
STEP 1

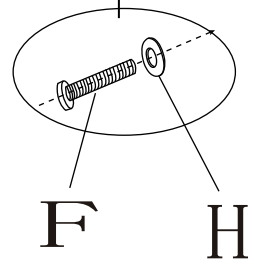
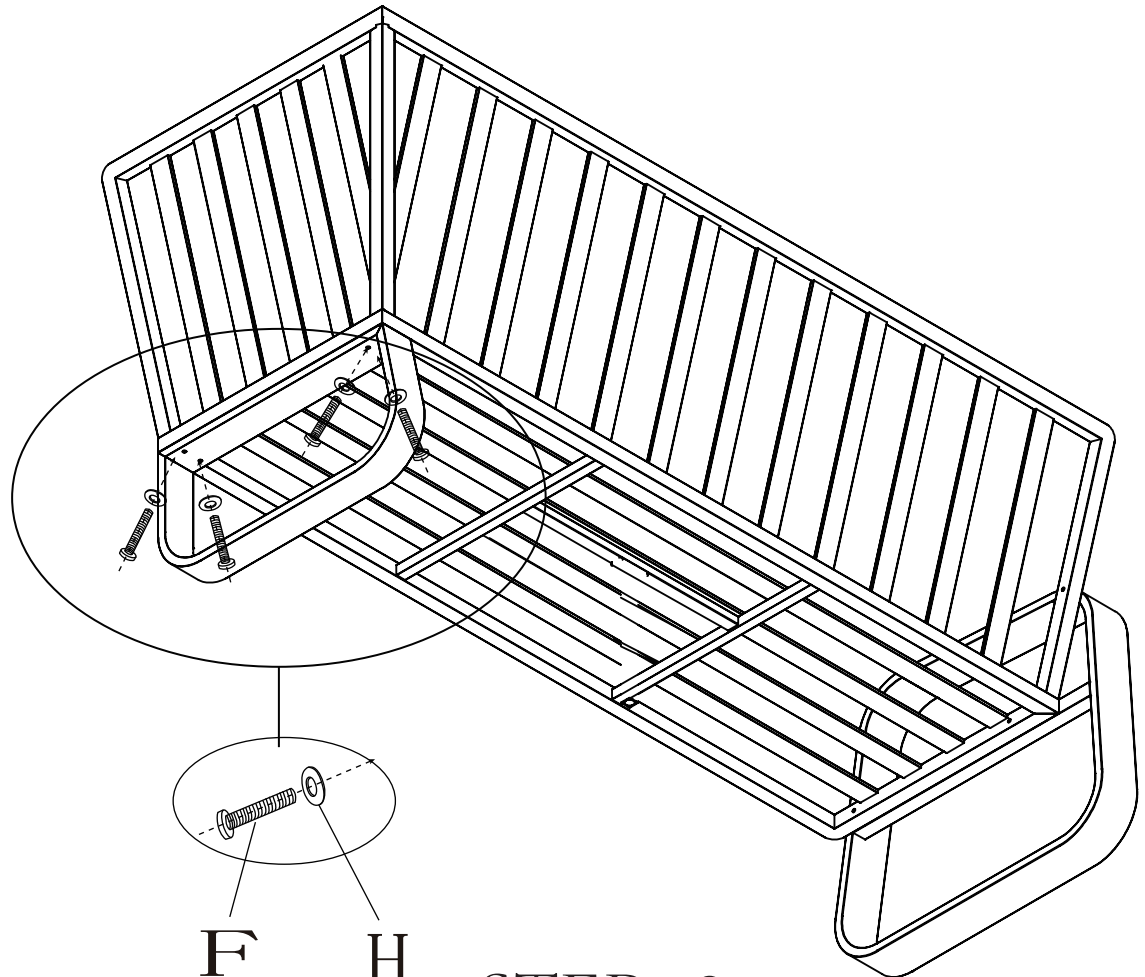



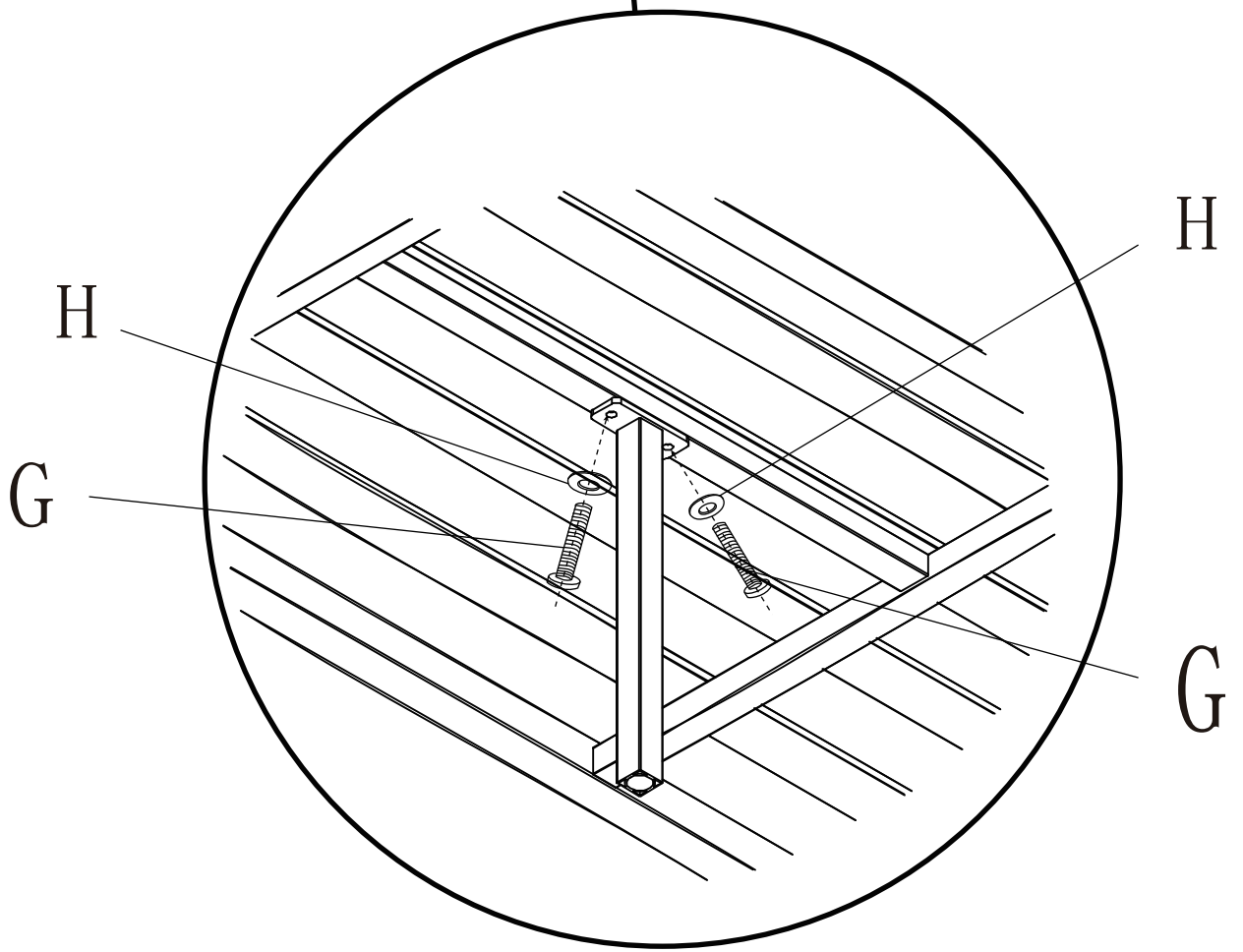
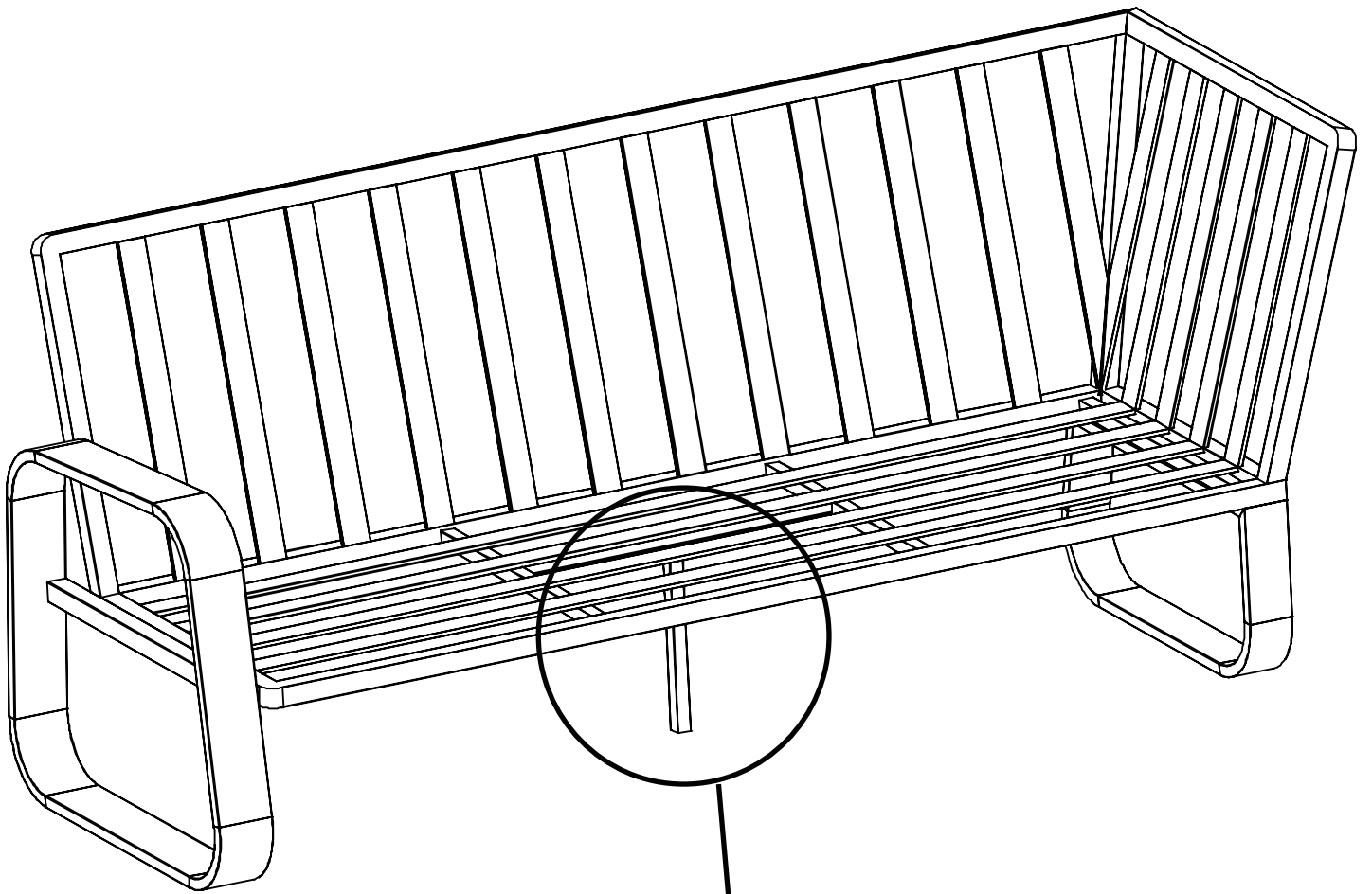





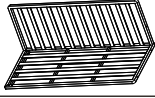

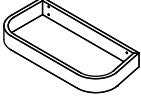
STEP 2

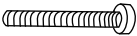

STEP 3

Assembly instruction

REF	PART NAME	PART IMAGE	QTY	REF	PART NAME	PART IMAGE	QTY
A	BACK BOARD		1	F	BOLT(M6X35)		4
B	TABLE LEG		1	G	BOLT(M6X15)		2
C	ARMREST		1	H	METAL WASHER		11
D	LEG		1	I	PLASTIC BOLT CAP		5
E	BOLT(M6X50)		5	J	ALLEN WRENCH		1

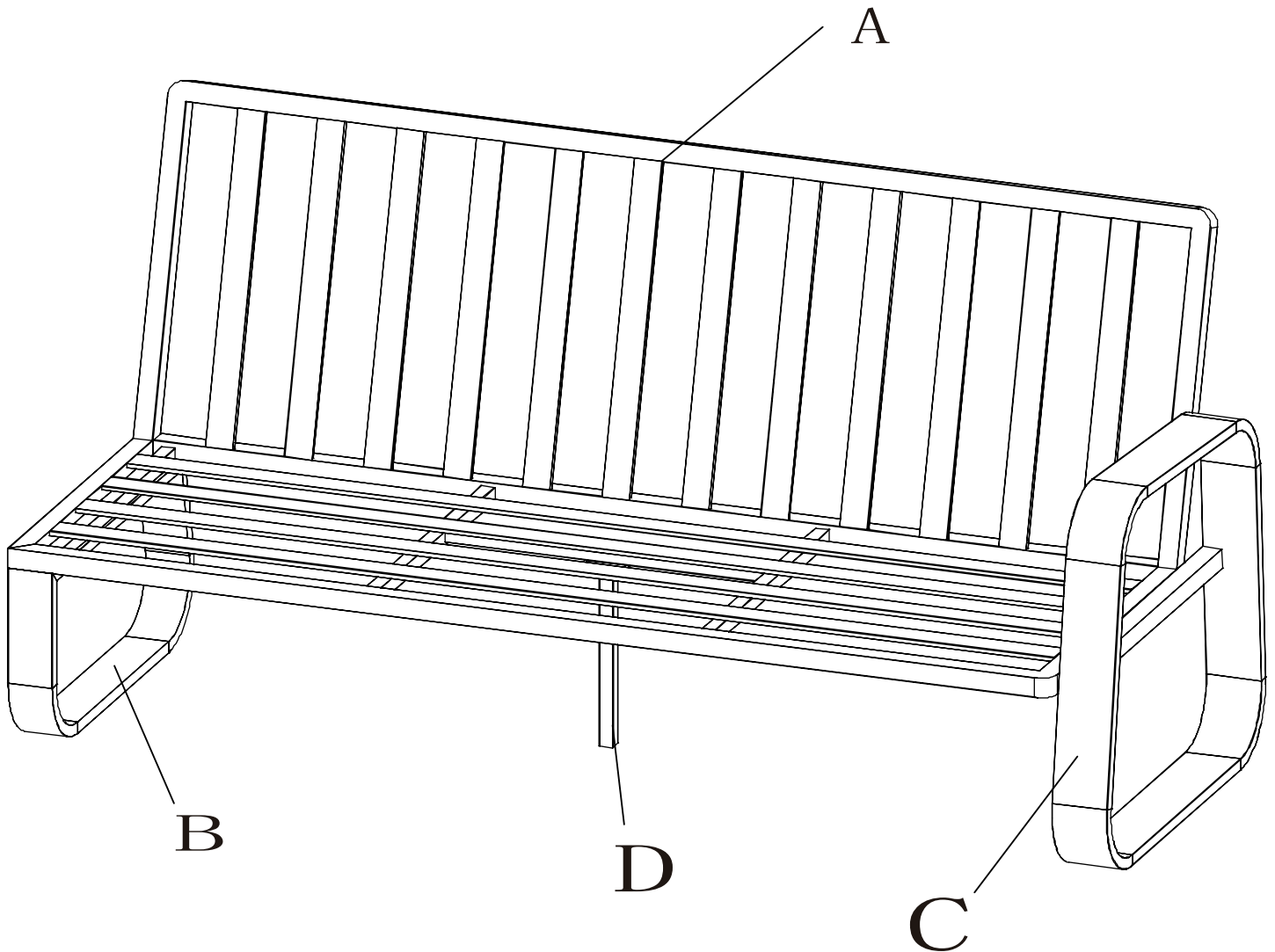

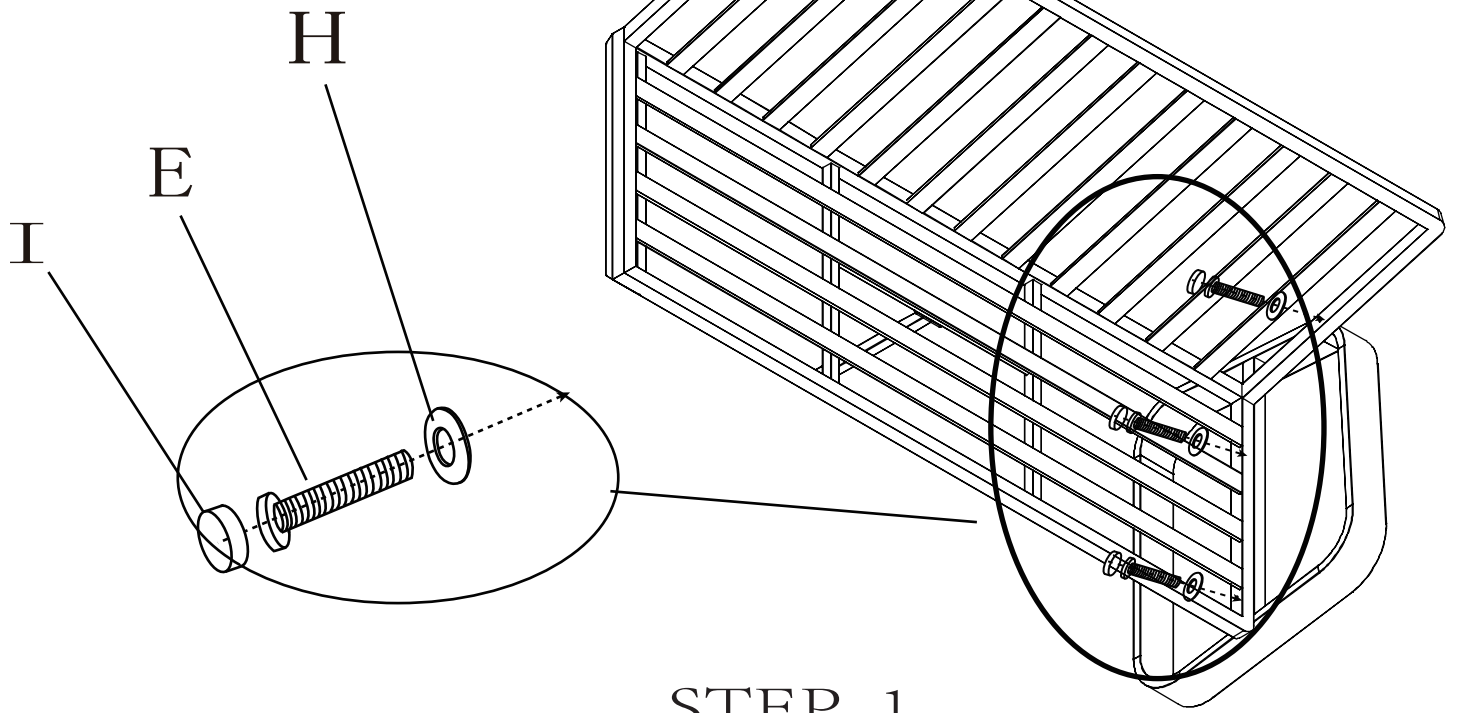

STEP 1

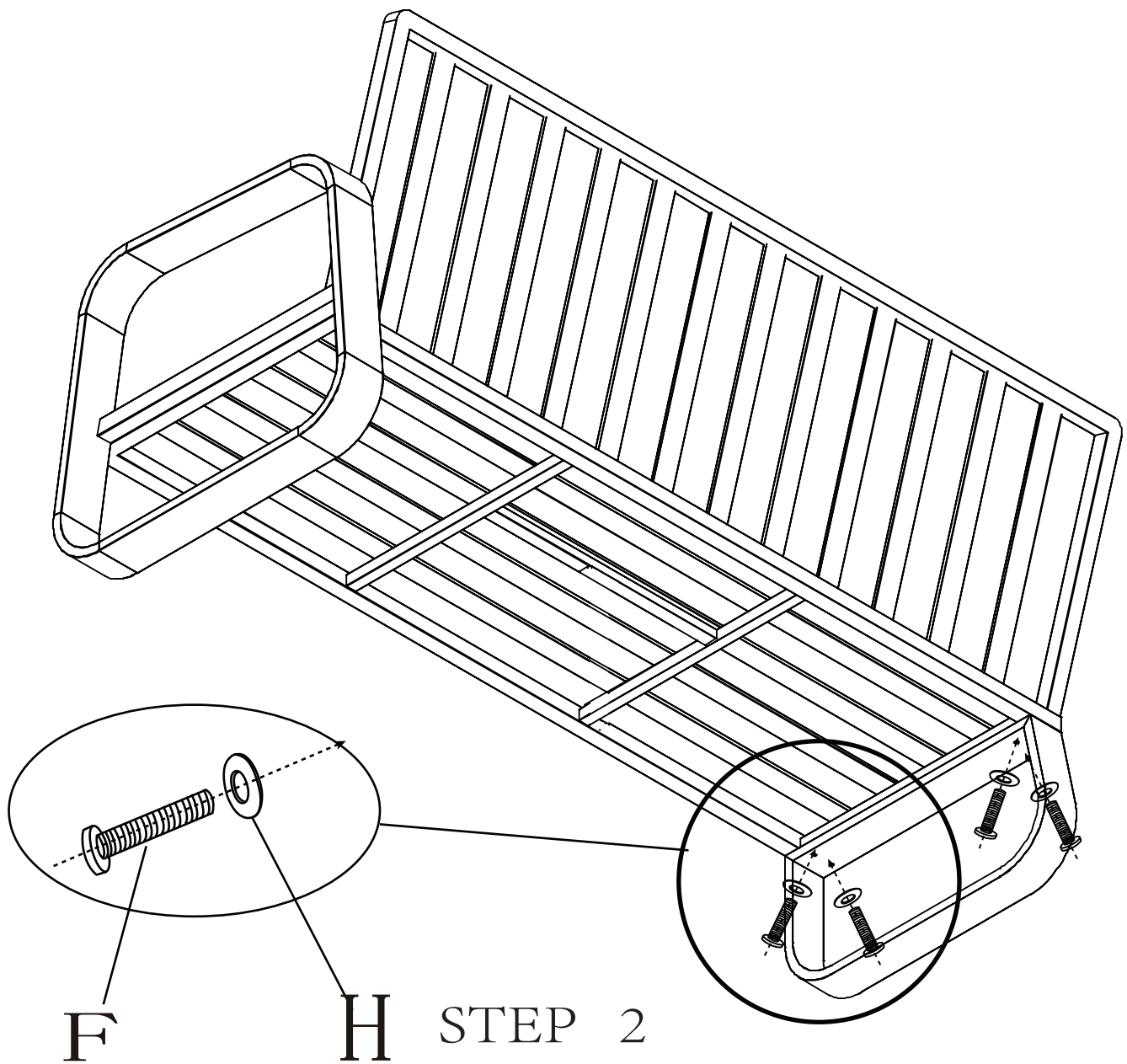

STEP 2

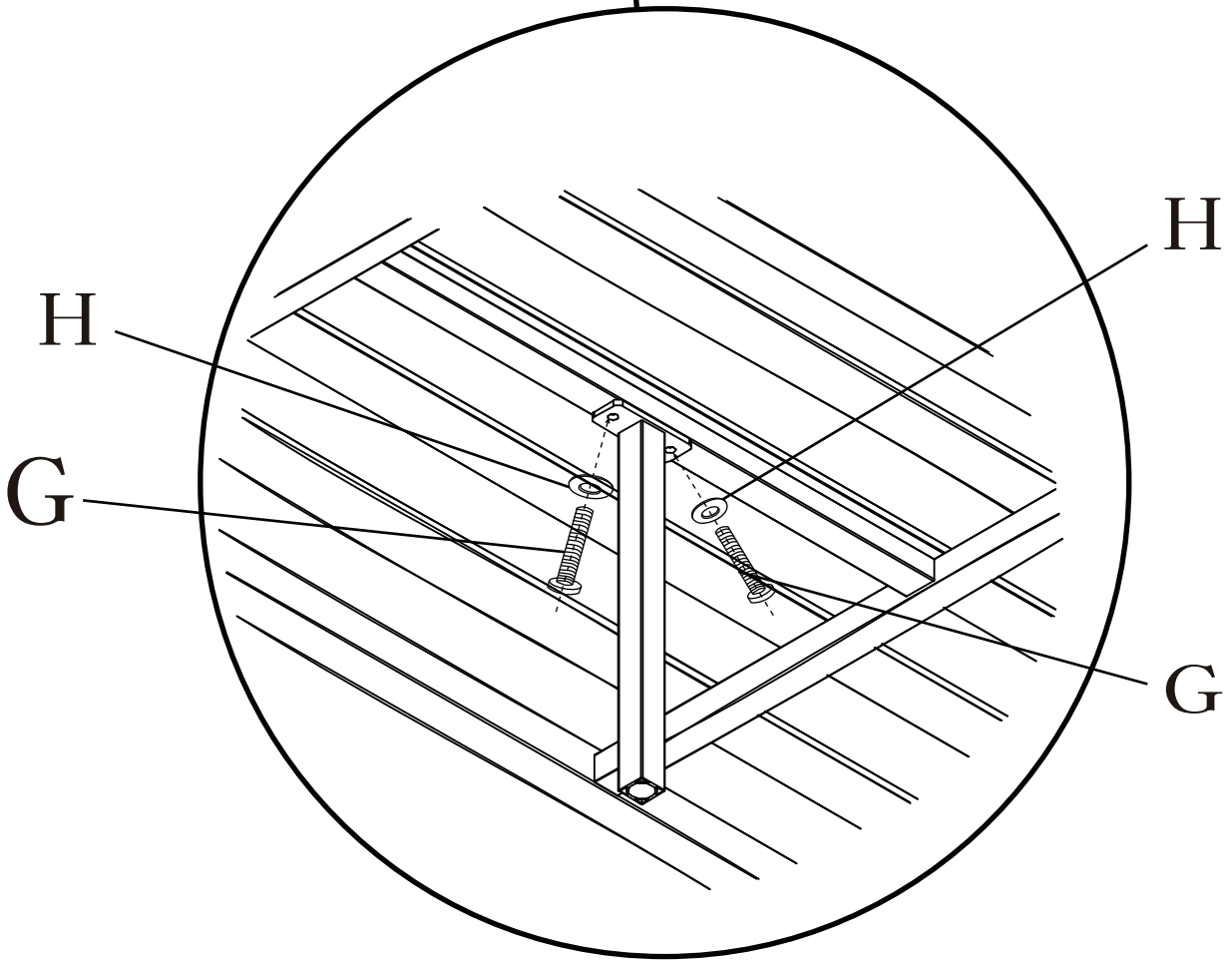
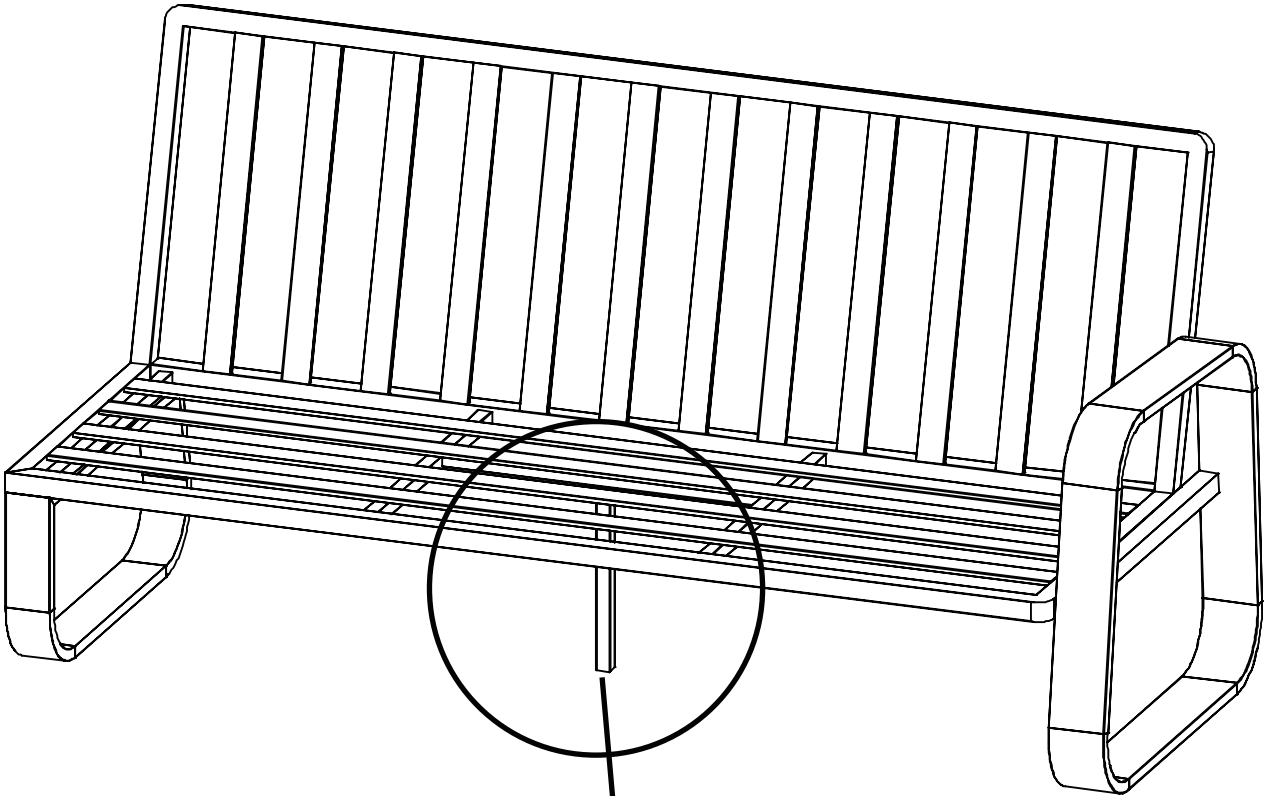



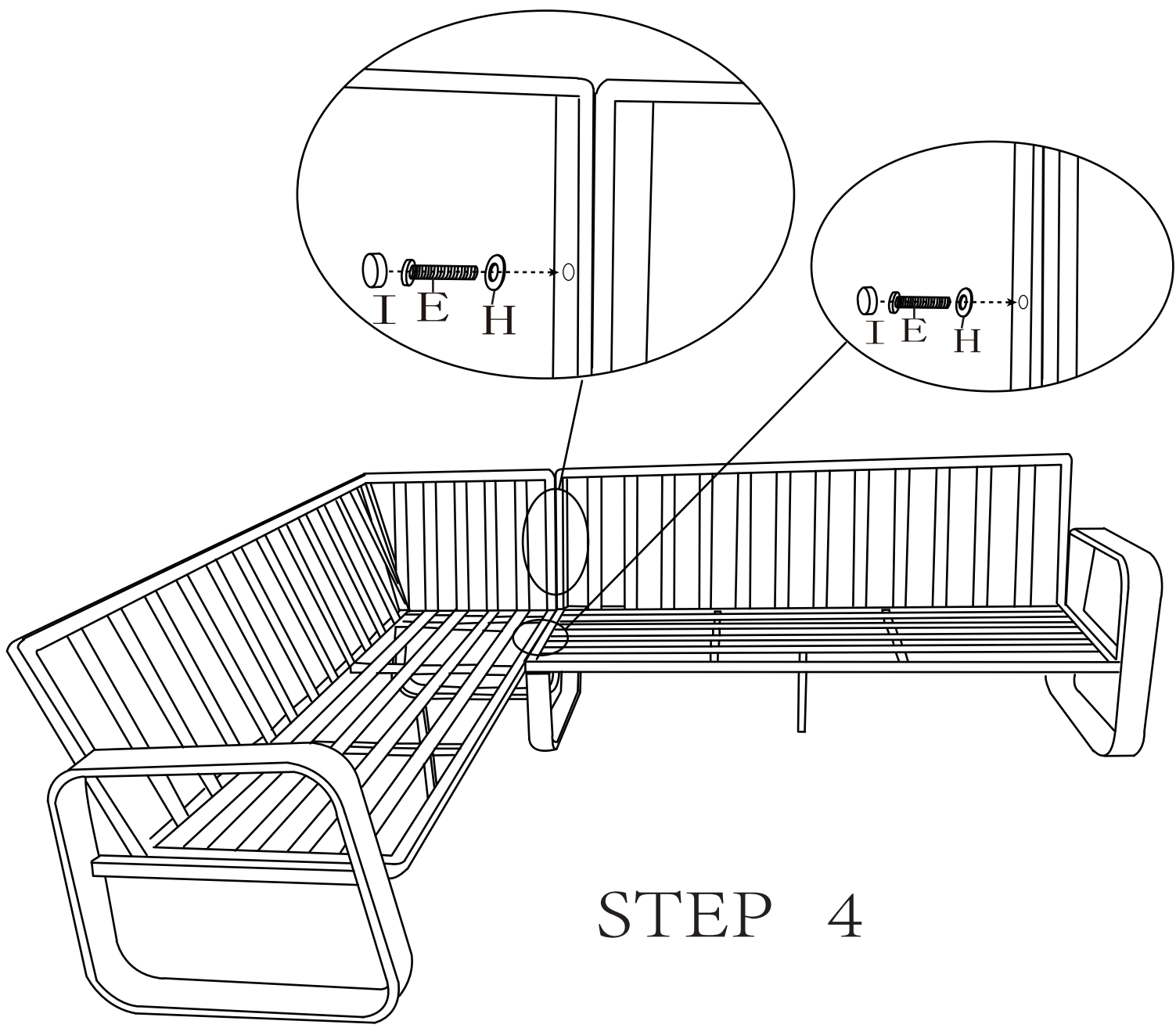



STEP 3



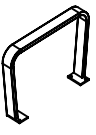

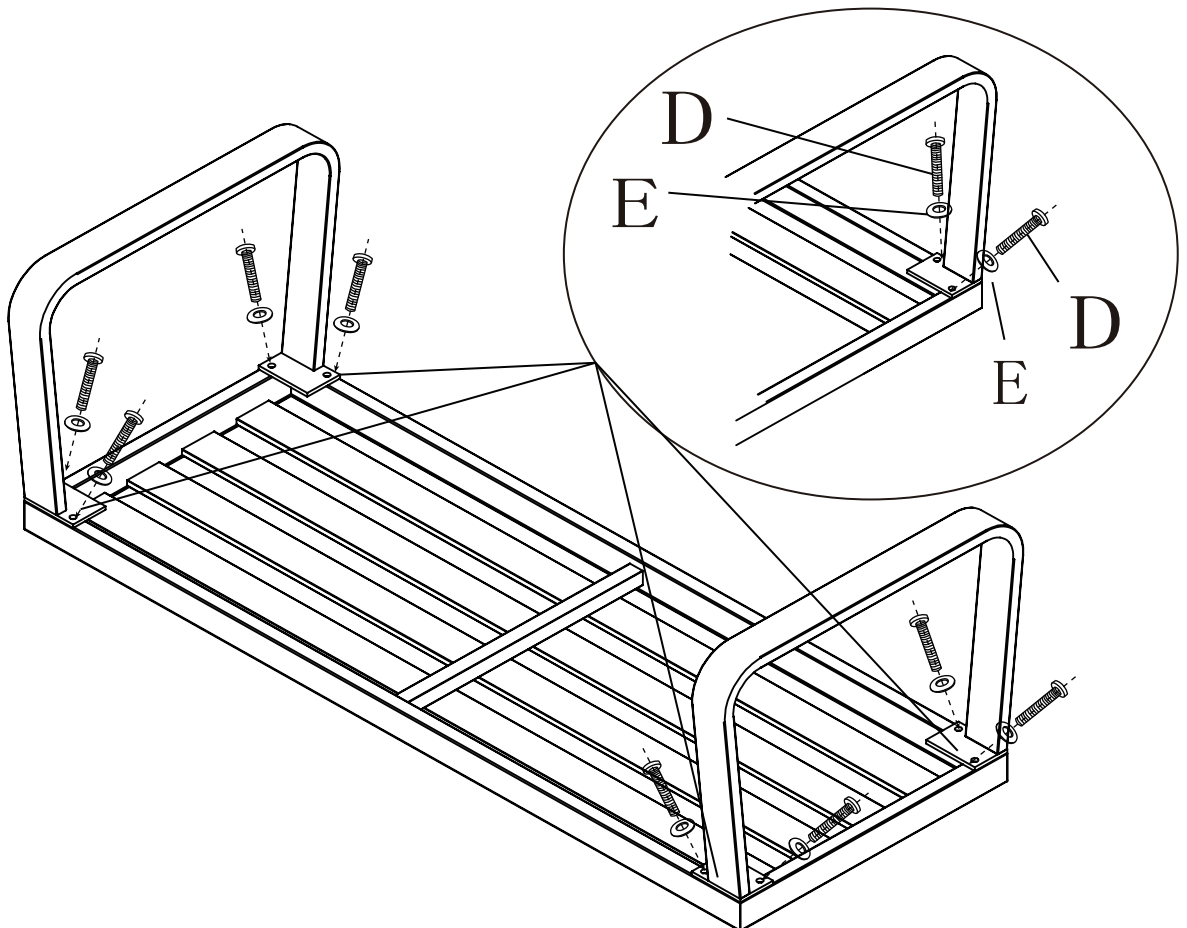
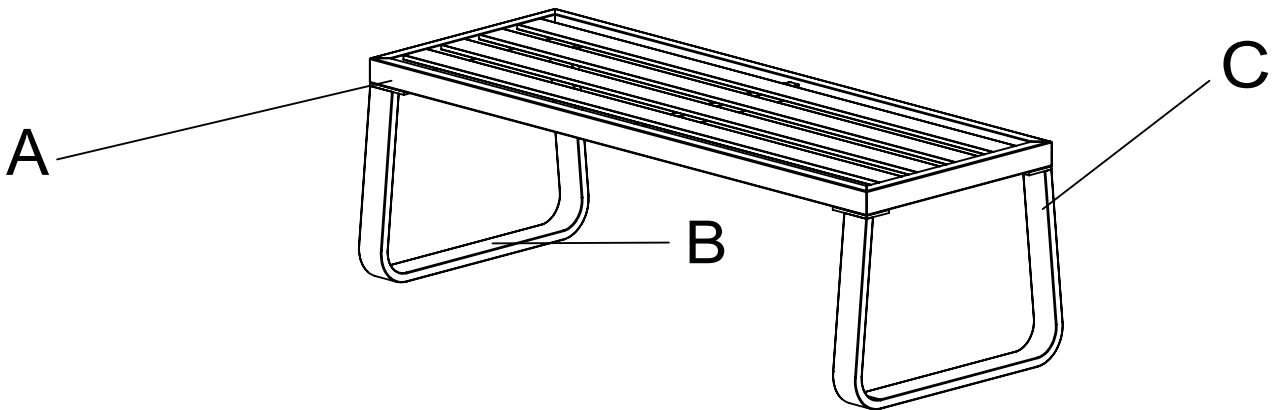

STEP 4

Assembly instruction

REF	PART NAME	PART IMAGE	QTY	REF	PART NAME	PART IMAGE	QTY
A	TABLE TOP		1	D	BOLT(M6X20)		8
B	TABLE LEG (1)		1	E	METAL WASHER		8
C	TABLE LEG (2)		1	F	ALLEN WRENCH		1

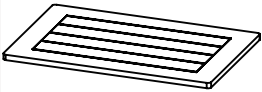

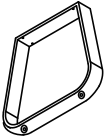
Assembly instruction

REF	PART NAME	PART IMAGE	QTY	REF	PART NAME	PART IMAGE	QTY
A	TABLE TOP		1	D	METAL WASHER		8
B	TABLE LEG		2	E	ALLEN WRENCH		1
C	BOLT(M6X30)		8				

